

METAL FINISHING MACHINES

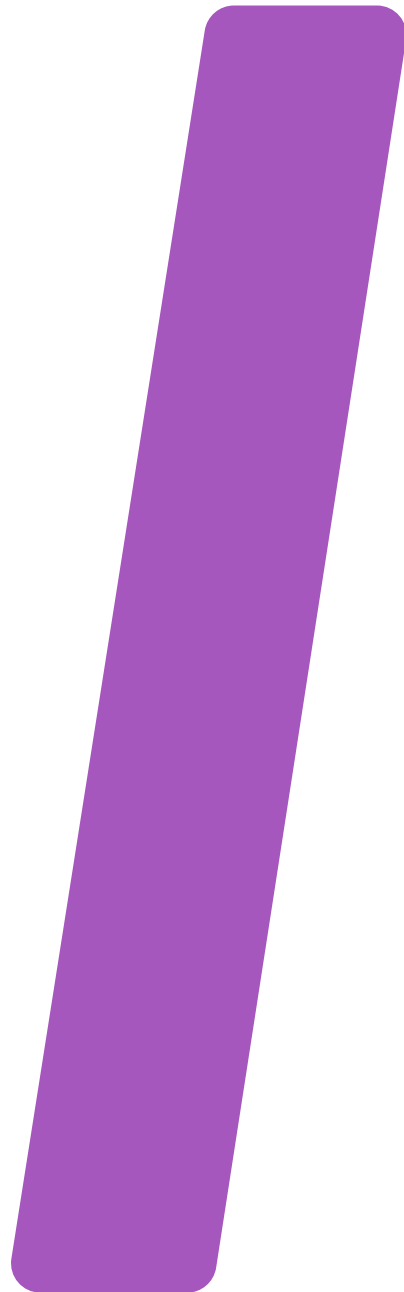

NS
MAQUINAS

INNOVATION AND EVOLUTION



WHERE?

NEXUS

CUSTOMERS
TESTS AND DEMONSTRATION

EVOLUTION
AUTOMATED MACHINES

PRODUCTION
ASSEMBLING AND R&D

DEVELOPMENT
CONTINUOUS IMPROVEMENT

PEOPLE
OFFICES

INNOVATION
NEW MODELS

SUPPLIERS
COMPONENTS

SOLUTIONS
INTEGRATIONS

ALL-ROUND PARTNER FOR METAL FINISHING

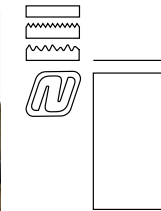

SHEET METAL DEBURRING
cut parts and sheet metal

EVO advanced deburring features

page 8

page 18

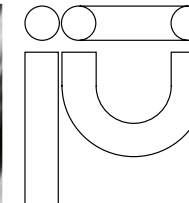

ROUND TUBE FINISHING
straight and bent tube

page 30

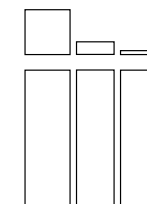

FLAT SURFACES FINISHING
flat bar and rectangular tube

page 42

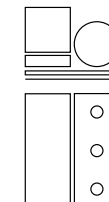

FINISHING, MIRROR POLISHING AND DRILLING
multipurpose

long belt finishing machines

page 60

mirror polishing machines

page 62

drilling machines

page 66

belt grinding universal machines

page 70

page 72

REFINING SURFACES, MASTERING EVERY EDGE

We take pride in our range of machines and in providing crafted solutions to address the industry needs.

The Nexus building is a manifest of our dedication to fostering an environment of continuous evolution, development, and innovation, all centered around providing optimal solutions for the market.

With our customer-centric approach, we aim to facilitate seamless progress and success within the metal fabrication industry.

SOLID ENGINEERING

We are renowned for the robust engineering as well as delivering reliable and adaptable machines for the most demanding markets.

Designed for durability, easy maintenance and optimal performance, our machines provide ample operational capacity, accommodating diverse production needs.

“We put all of our machines through a grueling pace throughout a day (...). A lot of them are running 24/7 and we haven’t had any problem with them at all. Plus, we’re actually running them outside of the envelope the machine was designed for.”

Kevin Harding, Camdel Metals Corporation, USA, about the ML100 3Z

CONSTANT INNOVATION

We continually pioneer the design and production of machines for the metal finishing and deburring markets. Our dedicated engineering team ensures that we drive this evolution in-house.

This dedication to advancing technology is evident in the development of automated loading systems, as well as an approach to refine each machine generation, emphasizing efficiency and an ergonomic design.

MORE THAN 20 YEARS EXPERIENCE

With over 20 years of industry experience, NS Máquinas has established a global presence, with approximately 5000 machines operating across 60 countries.

We offer the widest range of metal finishing machines, catering to various production scales, from small workshops to continuous operation lines.

Backed by a robust technical and sales network spanning five continents, we provide comprehensive support from initial setup to ongoing technical assistance, ensuring efficient and timely service delivery.

SHEET METAL DEBURRING

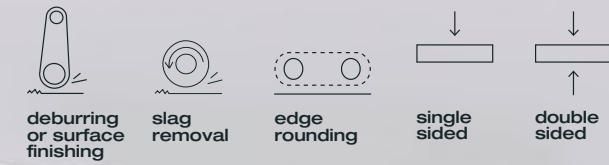

> **EDGE ROUNDING** unit both for small and large parts with abrasive cross belts

> **DEBURRING** heavy or light burrs, dross or slag after laser, plasma, shearing or punching with wide belt contact roller (Z) or with large deburring drum (D)

> **SINGLE AND DOUBLE SIDED EDGE ROUNDING OPERATION**

> **FINAL SURFACE FINISHING** with oscillating brush (K) or with non-woven wide belt (Z)

> **DIFFERENT WORKING WIDTHS** from 1100mm up to 1600mm

DM

DEBURRING SOLUTIONS

During sheet metal cutting processes performed by laser, punching, plasma or oxy-fuel cutting the edges of the cut parts often gain sharpness, a burr or even a heavy slag.

NS Máquinas has dedicated solutions for deburring and edge rounding either thin metal or thick metal sheets, in one side or on both sides of the workpiece.

Smoothing these inner and outer contours is often required both for safety and technical reasons.

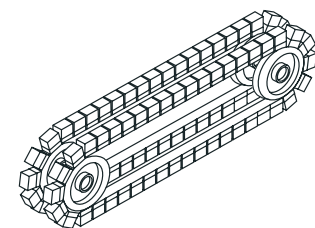

edge rounding **C**



__ a crossbelt system with counter-rotating abrasive blocks is used to make edge rounding on laser, punch, shear or waterjet cut parts

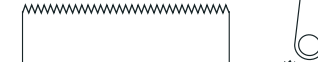
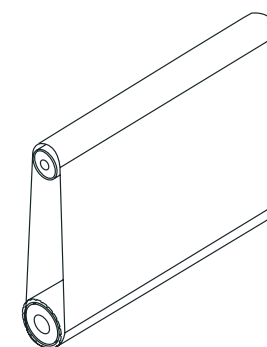

deburring **Z**

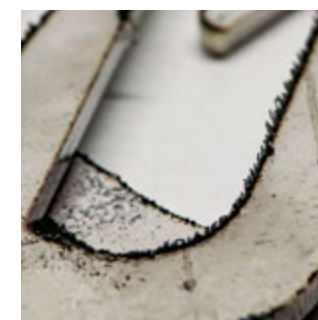

__ a wide belt abrasive unit is employed to remove burrs from the laser and plasma cutting process

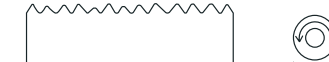
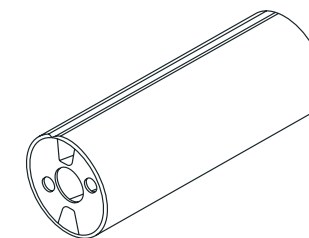

dross removal **D**



__ a larger diameter grinding contact drum is utilized to remove dross on thick steel plates from plasma and oxyfuel cutting

DM1100 C / EDGE ROUNDING
 ___ JOB-SHOP VERSION



___ two abrasive cross belts operating in opposite directions, completing edge rounding in every corner of the part



___ strong edge rounding on parts down to 50x50mm



___ parts return system improves productivity on small parts or double sided operation

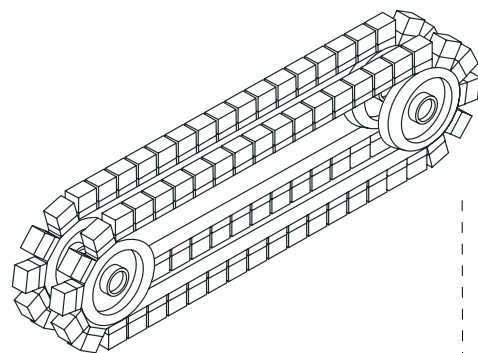

DM1100 C



DM1600 C



DM1100 Z / DEBURRING AND SURFACE FINISHING

___ JOB-SHOP VERSION

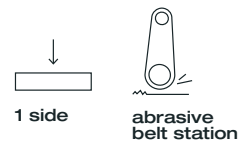

___ the abrasive belt station has a large diameter contact roller with Ø180mm diameter and 55SH, allowing for both deburring and finishing operations

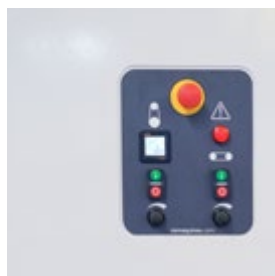

___ intuitive adjustments with a digital ammeter to check contact roller pressure

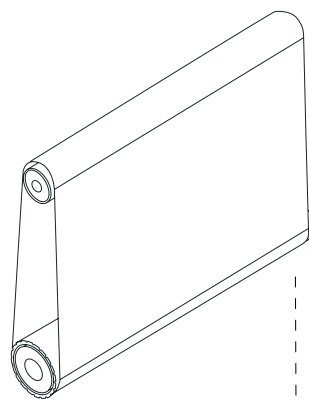

___ thickness is adjusted on an easy-to-use wheel with a 1/10mm precision display



___ the machine was developed to deburr metal parts cut by laser, punching or shearing

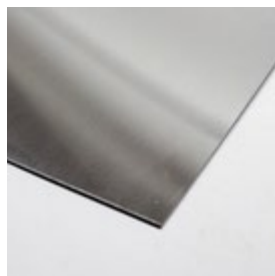
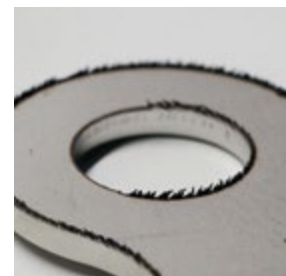

DM1100 Z

scan the QR CODE to watch the machine demonstration video

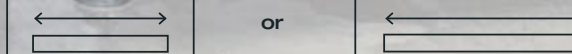

1100mm working capacity

___ DM1100 Z

or

1600mm working capacity

___ DM1600 Z

DM1100 ZC / DEBURRING AND EDGE ROUNDING
 __ JOB-SHOP VERSION

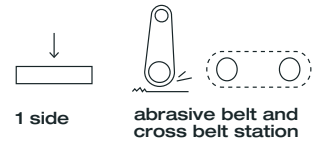

__ deburring and edge rounding with an abrasive contact roller and cross belt system

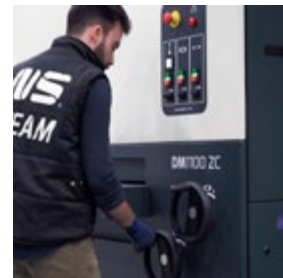

__ simple adjustments integrated on the machine for a quicker, more intuitive and reliable thickness and pressure

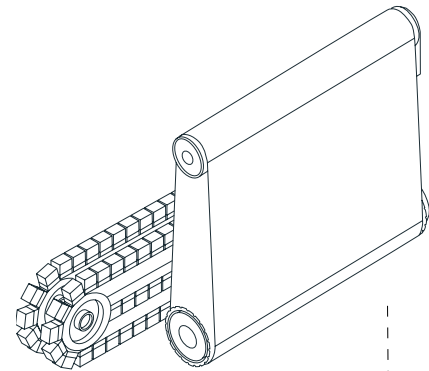

DM1100 ZC

DM1100 ZC
 __ JOB-SHOP VERSION

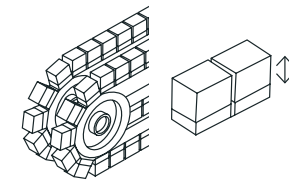
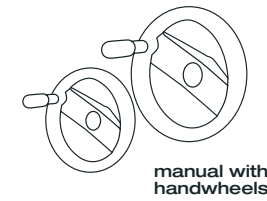
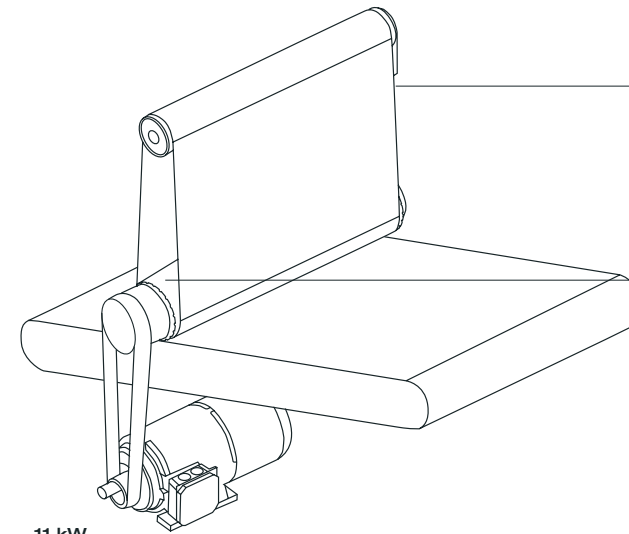

Quick manual reset of abrasive blocks wear.



__ learn more about the DM1100 ZC EVO option on page 22

scan the QR CODE to watch the machine demonstration video



EVO

ADVANCED DEBURRING FEATURES

EVO is improving our heavy-duty engineering principles, delivering powerful smooth deburring and edge rounding processes.

EVO is our next-level approach to sheet metal deburring. EVO is elegant design, keeping the integration of peripheral loading/unloading systems and automation equipment in mind.

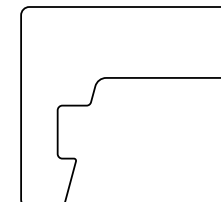

scan the QR CODE to watch EVO Line design and features



- _ heavy-duty engineering
- _ automated adjustments
- _ generous space for maintenance
- _ touchscreen control
- _ remote process monitoring
- _ interior lighting
- _ fixed working height

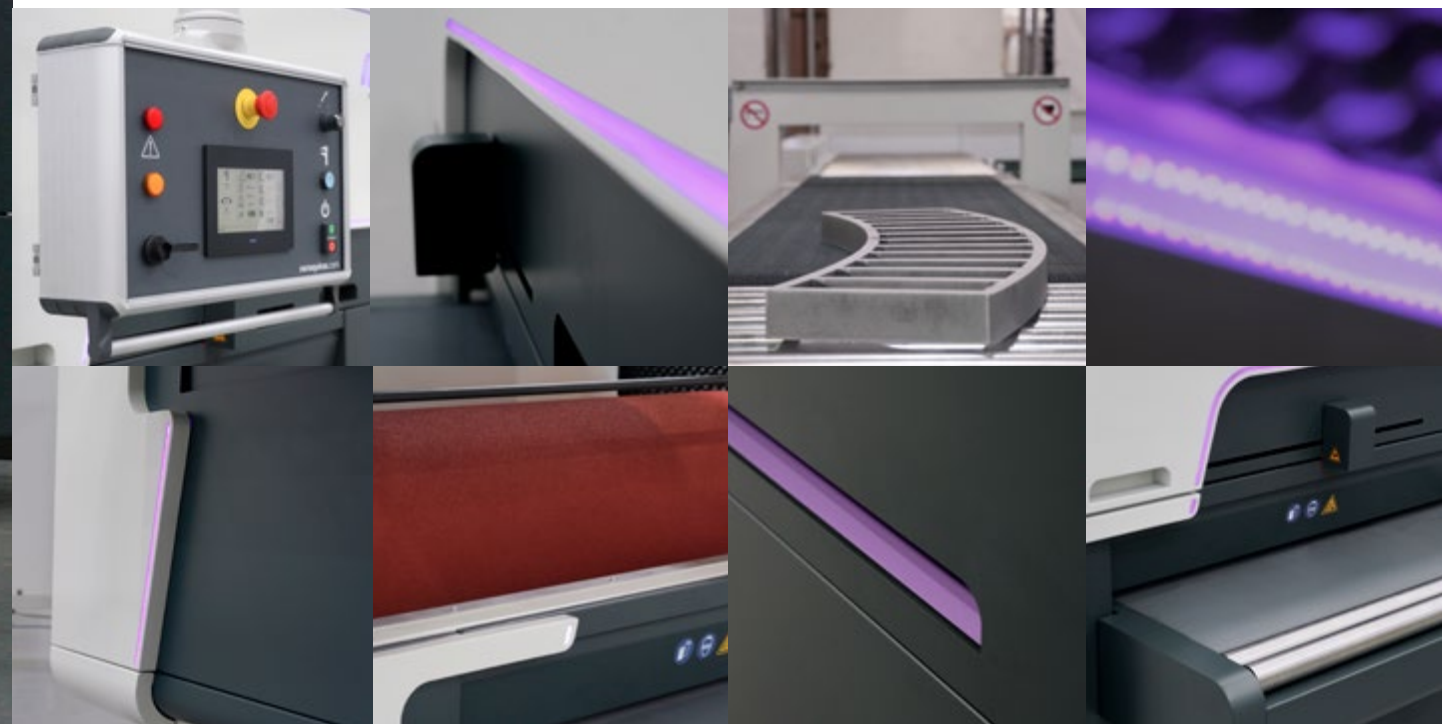

**DM1100 2C EVO / DOUBLE-SIDED
EDGE ROUNDING**

___ TOP LINE AUTOMATED

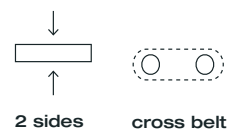

___ top and bottom
edge rounding of laser,
waterjet or punched
parts



___ single sided small
parts processing down
to 50x50mm thanks to
an additional conveyor
and support table

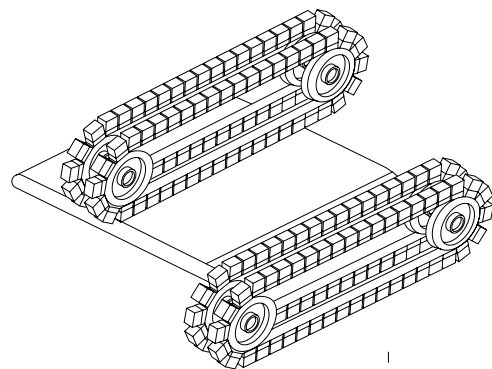

DM1100 2C EVO



scan the QR
CODE to watch
the machine
demonstration
video



DM1100 ZC EVO / DEBURRING AND EDGE ROUNDING
 TOP LINE AUTOMATED

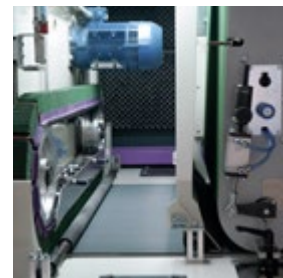
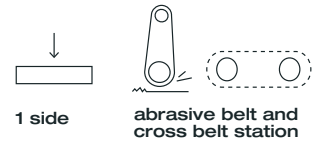

features a powerful deburring and edge rounding stations



strong edge rounding on parts down to (50x50mm)



special wide belt programs: deburring or surface finishing



DM1100 ZC EVO

DM1100 ZC EVO
 TOP LINE

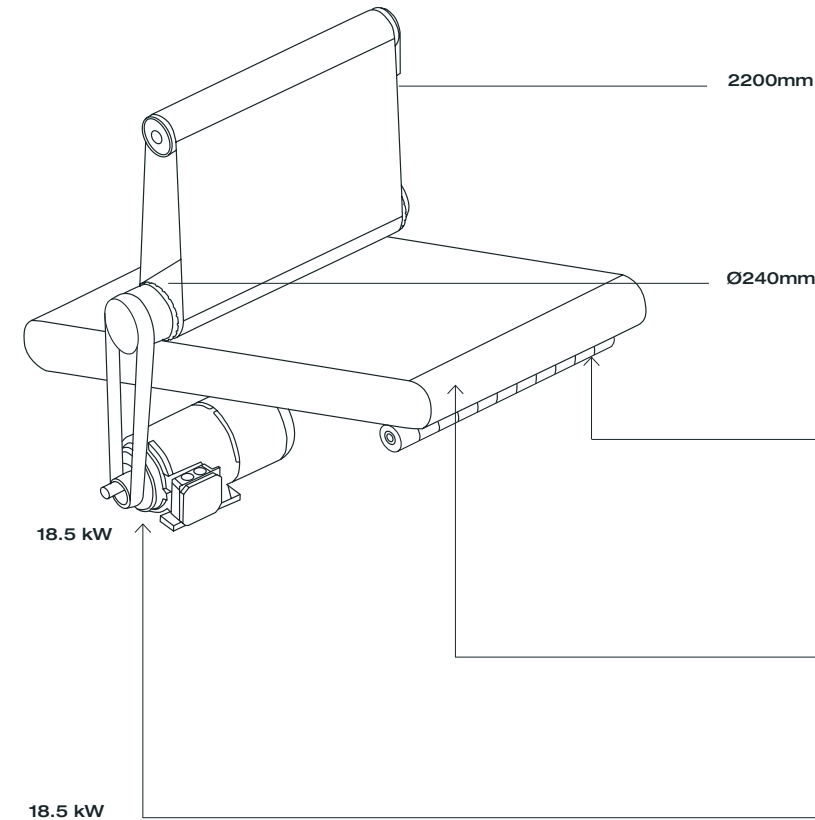

belt perimeter
 The longer belt ensures extended operational longevity, effectively minimizing downtime.

contact roller
 A bigger contact roller increases the grinding capacity to remove burrs or making surface finishing.

cleaning brush
 While running, the conveyor belt passes through a cleaning brush to remove debris and dust allowing for better grip of the parts during operation.

fixed working height
 Allows an easy integration of loading and unloading tables with the machine.

motor power
 Consistently delivers extended high-performance capabilities for various grinding tasks.



control
 Most of the controls are on the touchscreen panel without the need to manually adjust the parameters. Includes statistics and errors during and about the operation.

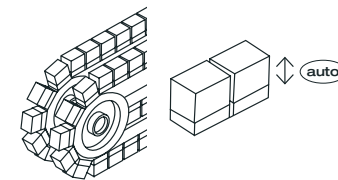

auto abrasive compensation
 Automatic abrasive wear compensation cycle to ensure uniform rounding.



DM1100 DC EVO / SLAG REMOVAL
 ___ HEAVY-DUTY AUTOMATED



___ heavy burrs deburring and edge rounding



___ possibility of regulating which stations will work and at what speed, the working pressure for both stations, floating drum on/off and drum oscillation

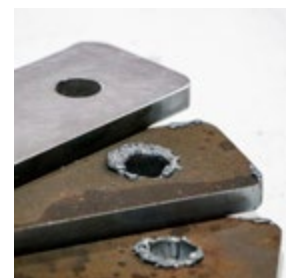

___ smooth edges
 two cross belts mounted with abrasive blocks running in opposite directions

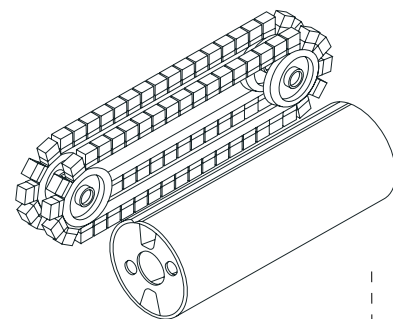

DM1100 DC EVO



scan the QR CODE to watch the machine demonstration video

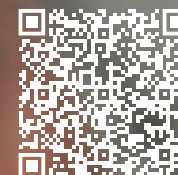

DM1100 2Z EVO / SURFACE FINISHING

___ TOP LINE AUTOMATED



___ double or triple abrasive belt station plus finishing brush (2ZK and 3ZK)

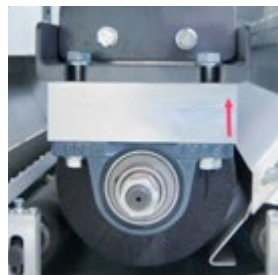

___ brush unit with option to be used with oscillation (150 strokes/min)

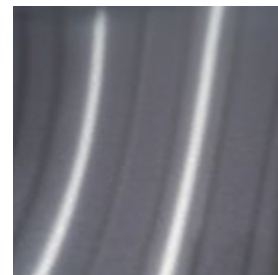

___ consistent and smooth surface finishing

dry version



water version

DMW1100 2Z EVO / SURFACE FINISHING

___ TOP LINE AUTOMATED

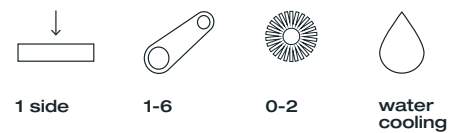

___ independent stainless steel compartments for each finishing station



___ the automatic filter assures the continuous renovation and monitoring of the filter paper cleanness

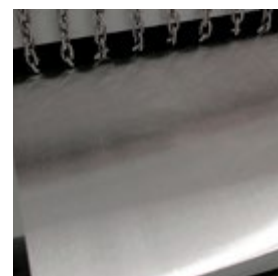

dry version

water version

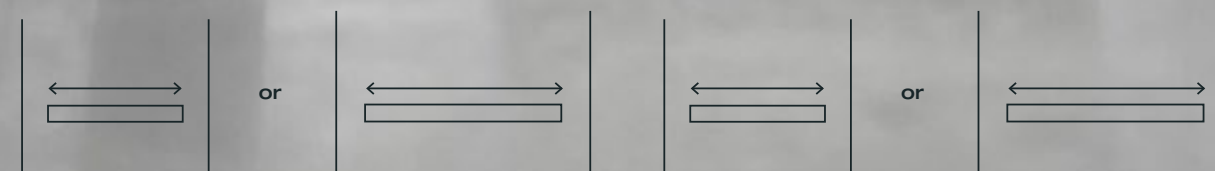

1100mm working capacity

1600mm working capacity

1100mm working capacity

1600mm working capacity

___ DM1100 2Z EVO

___ DM1600 2Z EVO

___ DMW1100 2Z EVO

___ DMW1600 2Z EVO



EDGE ROUNDING

	C	C EVO
category	job-shop version	automated functions
available width (mm)	1100 1600	1100 1600
operation type	single-sided	single-sided double-sided

DEBURRING AND SURFACE FINISHING

	Z	ZC	ZC EVO	DC EVO	Z EVO
category	job-shop version	job-shop version	top line automated	heavy-duty automated	top line automated
available width (mm)	1100 1600	1100 1600	1100 1600	1100 1600	1100 1600
edge rounding mode	×	single-sided	single-sided double-sided	single-sided double-sided	×
deslagging level	●○○	●○○	●●○	●●●	×
deburring level	●●○	●●○	●●●	●●●	×
surface finishing level	●●○	●●○	●●●	×	●●●
not suitable ×	limited ●○○		adequate ●●○		optimal ●●●

ROUND TUBE FINISHING



planetary system



1-6 no. of stations



dry/water cooling



straight tube



bent tube



> **ML PLANETARY SYSTEM**
Abrasive belt finishing without rotating the tube. Low heat and no vibration on the tube

> **TUBE SUPERIOR QUALITY**
in satinising and finishing of round tubes and pipes. Ultimate versatility for oval, drilled, tapered and bent tubes

> **SINGLE OR MULTIPLE STATION DESIGN:** 1 up to 6 units (6Z)

> **DIFFERENT DIAMETER CAPACITIES** up to Ø350mm

> **MACHINES AVAILABLE IN DRY AND IN WATER** configurations with manual or automatic water cooling and filtration system

> **MOBILE TOUCHSCREEN** for easy machine control with the option for programs saving

> **AUTOMATIC LOADING AND UNLOADING** systems for autonomous operation



ML

STRAIGHT AND CURVED TUBE FINISHING

ML planetary system is suitable for straight and curved tubes finishing. In this operation the tube is not spinning since the abrasive belts rotate around the tube while it is safely transported by the feeding systems, guaranteeing low vibration and low heat.

By sliding the feeding units, it is possible to process curved tubes manually. The operator simply guides the tube through the machine while the abrasive planetary system performs the finishing in the complete diameter of the tube.

- _ minimum vibration even on longer tubes
- _ straight or curved tube polishing
- _ low heat

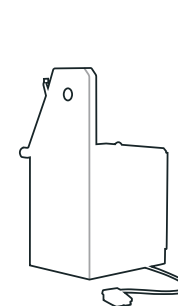
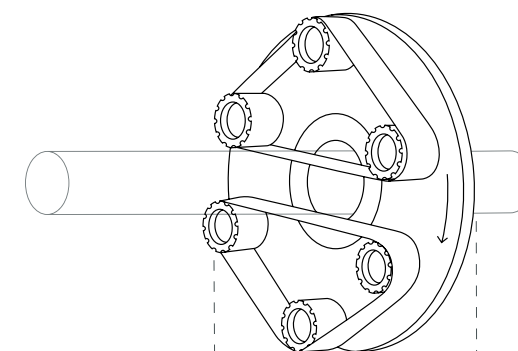

ML50 Ø 50mm

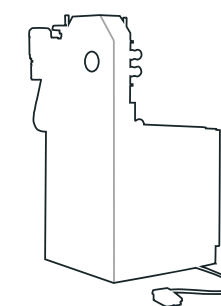

ML75 Ø 76mm



ML100 Ø 114mm



scan the QR CODE to see the machine demonstration video



LARGE DIAMETERS / ROUND TUBE FINISHING MACHINE

ML150

Ø 150mm

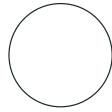

— automatic finishing of straight round tubes through the feeding system

ML200

Ø 205mm

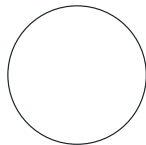
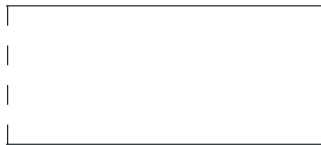

— the automatic feeding system is hinge mounted and easily removable for bent tube finishing

ML300

Ø 310mm

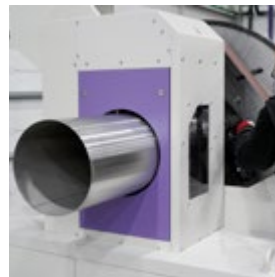
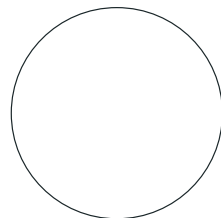
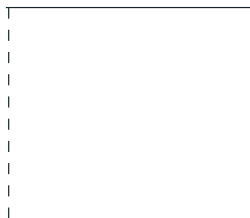

— strong and solid design of the feeding systems for straight tubes

ML350

Ø 350mm

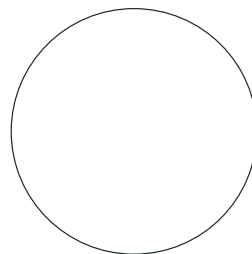

— remove imperfections by using the contact pressure roller on the abrasive belt for higher pressure

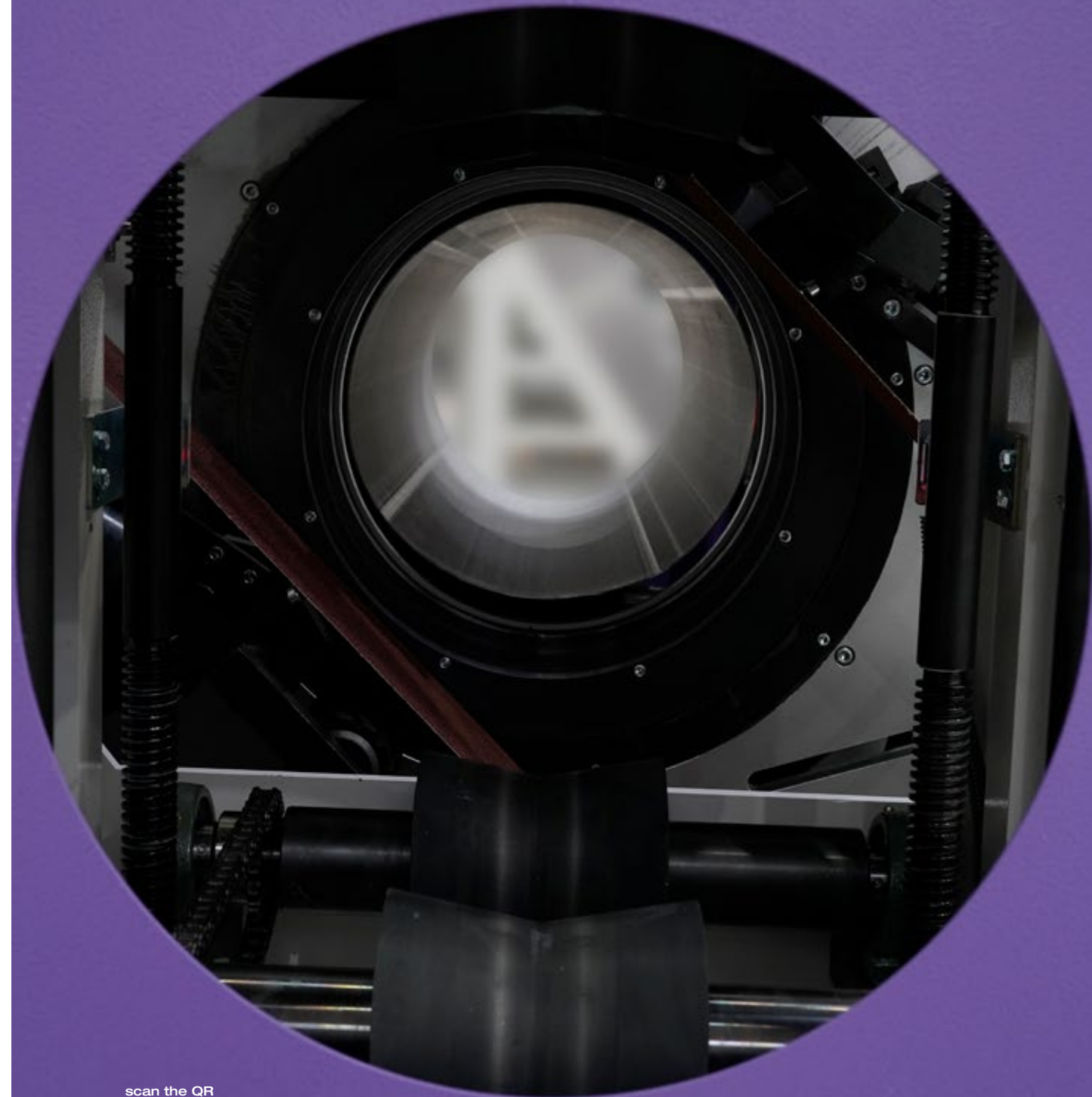

scan the QR CODE to watch the machine demonstration video



ML350

ROUND TUBE

MULTIPLE STATIONS / ROUND TUBE FINISHING MACHINE



Ø 114mm



2-6



water version

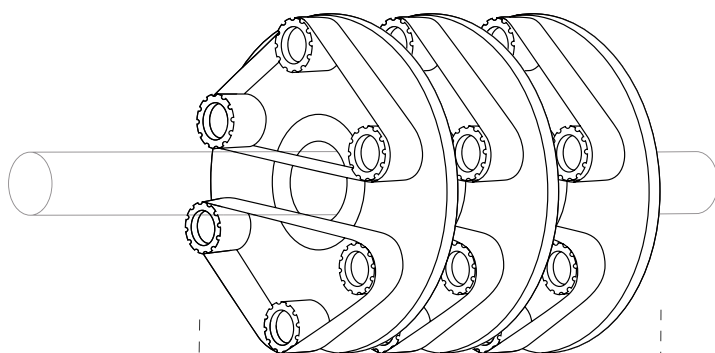

dry version

or

water version



ML100 2Z



MLW100 3Z

__ simpler maintenance and setup: reduced complexity and straightforward operation

__ easily exchange between various metals, reducing the risk of corrosion

__ dust extraction: an external dust extraction unit manages and removes dust generated during grinding process - this maintains a clean and safe workspace

__ cooling: water is sprayed onto the finishing area to reduce heat generated during grinding and improving safety on potential explosive materials

__ dust suppression: water controls dust generated during the grinding process, creating a cleaner and safer work environment

__ closed circuit system: the machine can integrate a manual or automatic filtering system, minimizing water wastage



MLW100 6Z AT / AUTOMATIC PROCESS ROUND TUBE FINISHING MACHINES

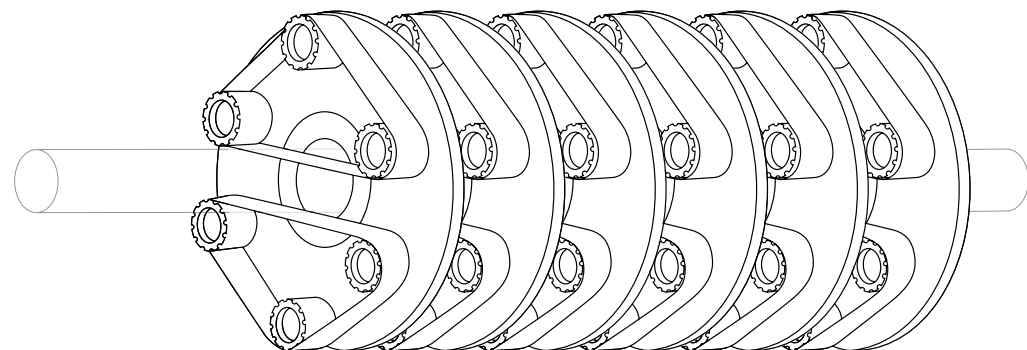
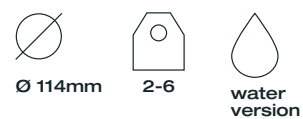

MLW100 6Z AT



— water cooling system
to reduce the temperature of the tubes during the finishing operation

— automatic loading and unloading systems with option for programs saving

— great savings in handling time and operator intervention



TUBE TRANSPORT SYSTEMS



conveyor type

operator feeds the loading table with tubes one by one, avoiding contact between them



bundle type

load and unload complete bundles of tubes without the need for individual feeding

scan the QR CODE to watch the machine demonstration video



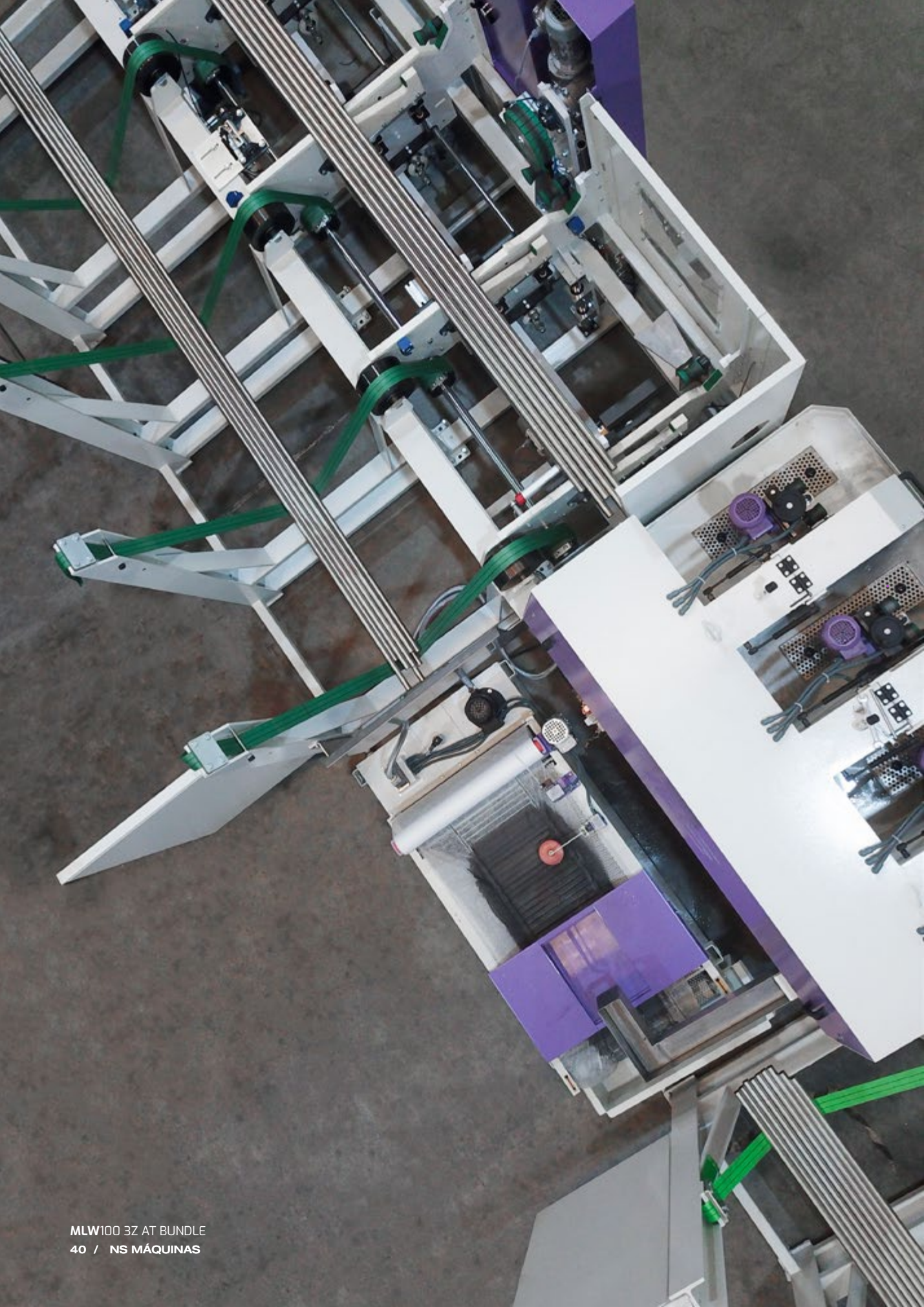

DRY OPERATION

	ML50	ML75	ML100	ML100 Z	ML150 + ML200	ML300 + ML350
diameter capacity (Ø mm)	5-50	10-76	10-114	10-114	20-150 20-205	40-310 60-350
no. of stations	1	1	1	2-3	1	1
bent tubes	✓	✓	✓	✗	✓	✗
abrasive belt dimensions (mm)	25x500	25x860	50x940	50x940	50x1100 70x1240	120x2150 120x2300

WATER OPERATION

	MLW100	MLW100 Z	MLW200	MLW200 Z
diameter capacity (Ø mm)	10-114	10-114	20-150	20-205
no. of stations	1	2-6	1	2-6
bent tubes	✓	✗	✓	✗
abrasive belt dimensions (mm)	50x940	50x940	70x1240	70x1240

RECTANGULAR TUBE AND BAR FINISHING

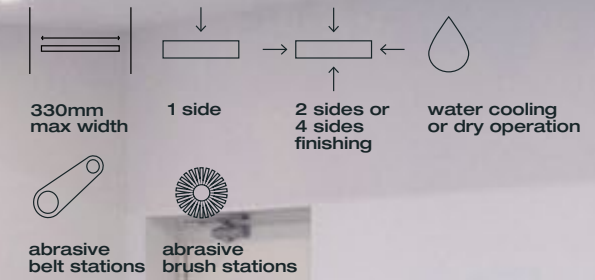

> **BELT (Z) OR BRUSH (K)** options displayed in variable sequences

> **WIDE CHOICE** models from 120mm up to 330mm width

> **MACHINES AVAILABLE IN DRY AND IN WET CONFIGURATIONS** with manual or automatic water cooling and filtration system

> **SINGLE OR MULTIPLE STATION DESIGN:** 1 up to 6 units

> **FIXED WORKING HEIGHT** easy integration with support tables

> **POSSIBILITY TO EQUIP** with loading and unloading tables and conveyor return system for small parts operation

FC120 ZK / FLAT SURFACE FINISHING
__ JOB-SHOP VERSION

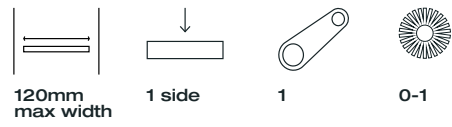

__ abrasive belt head surface finishing and imperfections removal for square and rectangular tubes, flat bars and small sheet metal



__ smooth finishing after belt grinding operation with non-woven brush



__ FC120 Z has one abrasive belt unit



__ compact machine with thickness meter with a precision of 1/10mm

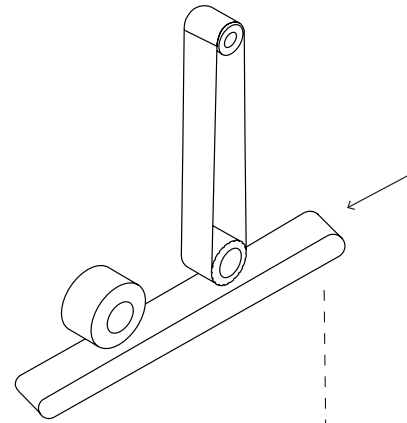

FC120 ZK

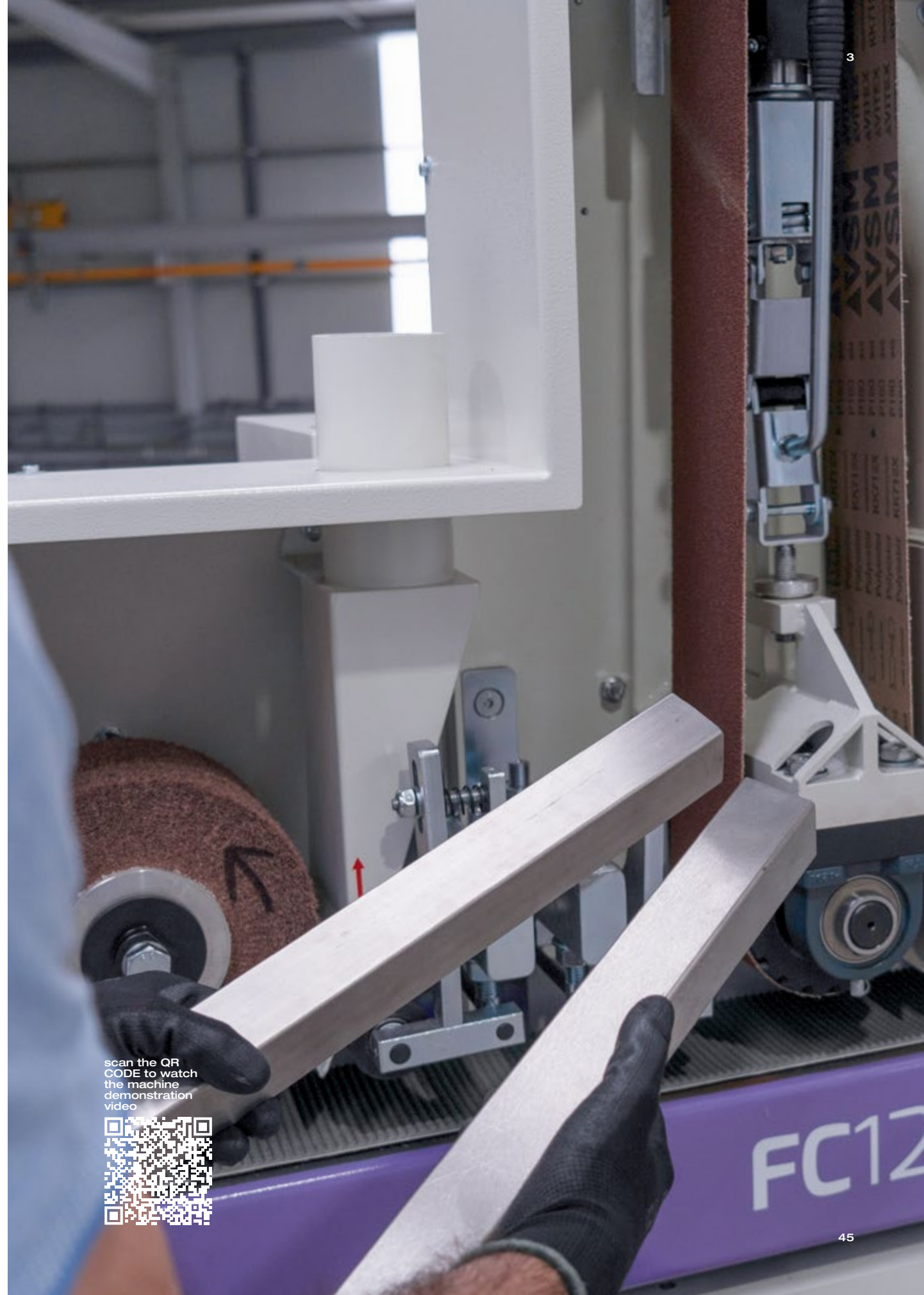

scan the QR
CODE to watch
the machine
demonstration
video



FLAT SURFACE FINISHING



FG170 2ZK

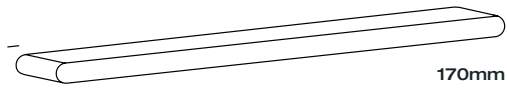
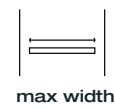

FG170

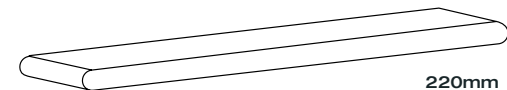

FG220

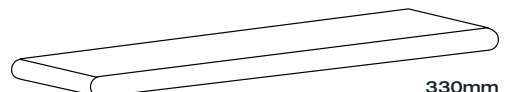

FG330

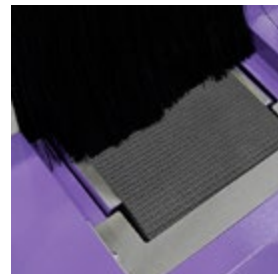

_ fixed working height
the adjustment for different thicknesses is made by the movement of the abrasive stations, keeping the conveyor belt always at the same level, this helps the work of long tubes and bars without having to adjust support tables

_ configure each machine
with different combinations of abrasive belt and brush stations for an optimum finishing level of tubes, bars and small sheet metal

FG ABRASIVE BELT AND BRUSH COMBINATIONS

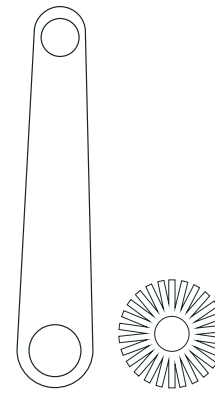

ZK
FG170 ZK

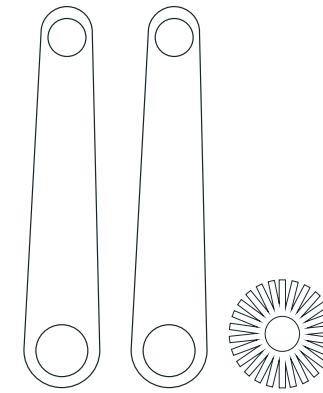

2ZK
FG220 2ZK
FG330 2ZK

FG SURFACE FINISHING EXAMPLES

before



→ after

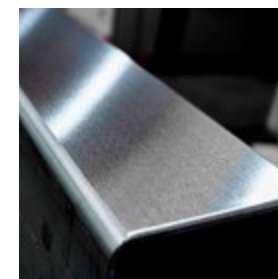

before



→ after

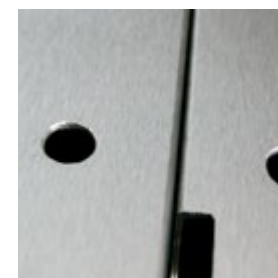

FG220 4ZV / FLAT SURFACE FINISHING

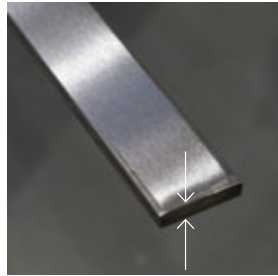
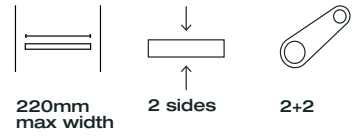

— finishes tubes and bars
on 2 sides simultaneously

— complete polishing of
the 4 sides of the square
tube in 2 passes only



— upper belt stations
permit independent work
of all abrasive stations,
making it possible to
operate only one side



— finishing of the bottom
side of the profile with
bottom stations

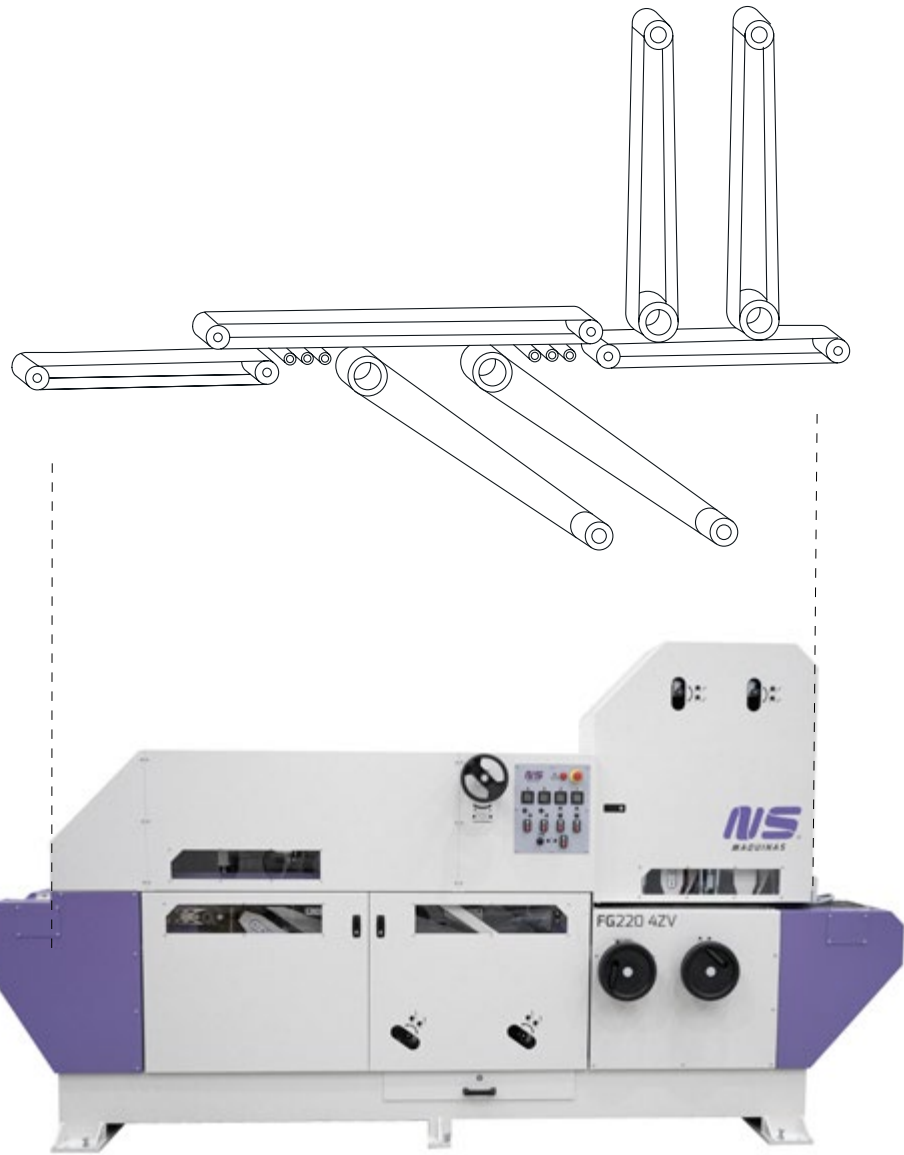

FG220 4ZV



scan the QR
CODE to watch
the machine
demonstration
video



RECTANGULAR
TUBE AND BAR

FCW120 Z / FLAT SURFACE FINISHING
— JOB-SHOP VERSION

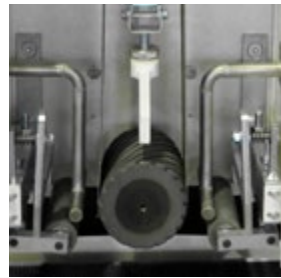
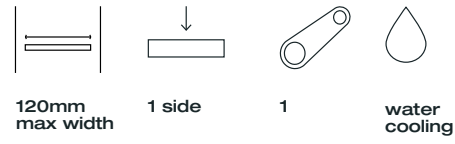

— abrasive belt head
surface finishing and
imperfections removal
for rectangular tubes and
flat bars



— quick and intuitive
machine control



— water cooling reduces
the heat on the grinded
material

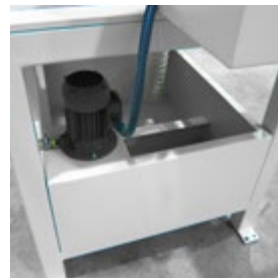

— tank and water pump:
cooling system in a
closed circuit

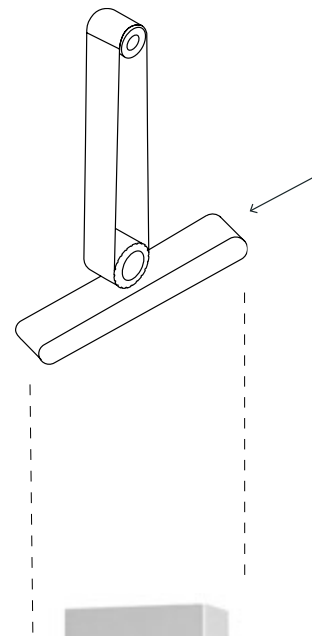
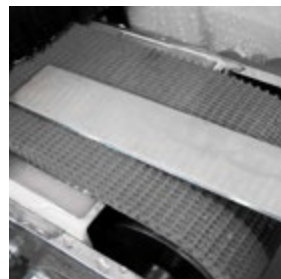

FCW120 Z



FLAT SURFACE FINISHING

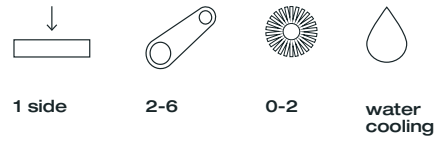

FGW170 3Z

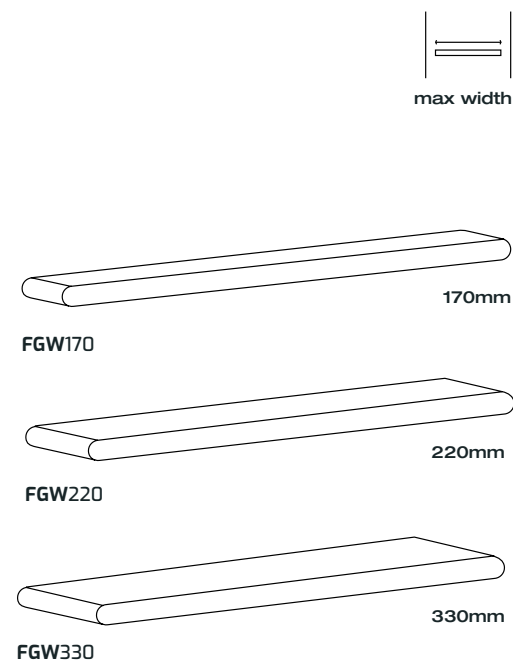

FGW ABRASIVE BELT COMBINATIONS

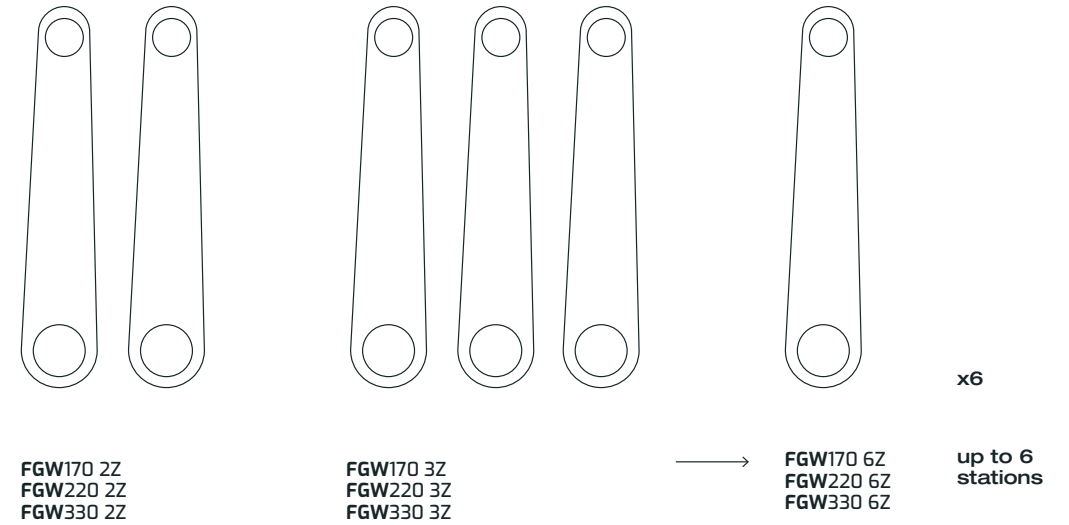

OPTIONAL FUNCTIONS



__ independent abrasive stations construction: accurate setting



__ high quality surface finishing on stainless steel tubes, tube after tube

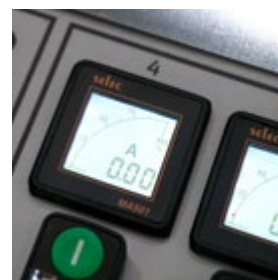

__ mobile control panel



__ standard manual filtration system integrated on the machine

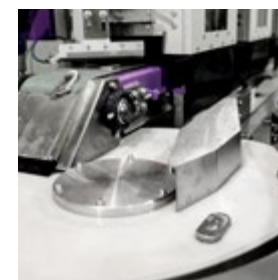

__ automatic return of small parts for single worker operation



__ automatic water filtration system provides an autonomous renovation and monitoring of the filter paper's cleanliness



__ air blower: reducing the quantity of splashes outside of the machine

FGW170 4ZV / FLAT SURFACE FINISHING

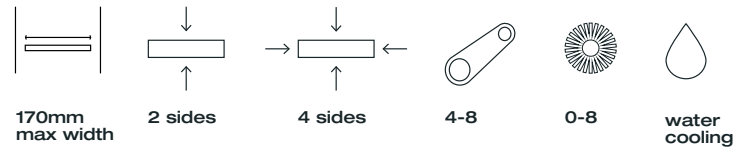

__ FGW170 4ZV
top and bottom finishing
of tubes, bars and
aluminum profiles in one
single pass



__ FGWH170 8Z
finishes all four sides
simultaneously



__ touchscreen panel for
automatic regulation with
programs saving feature

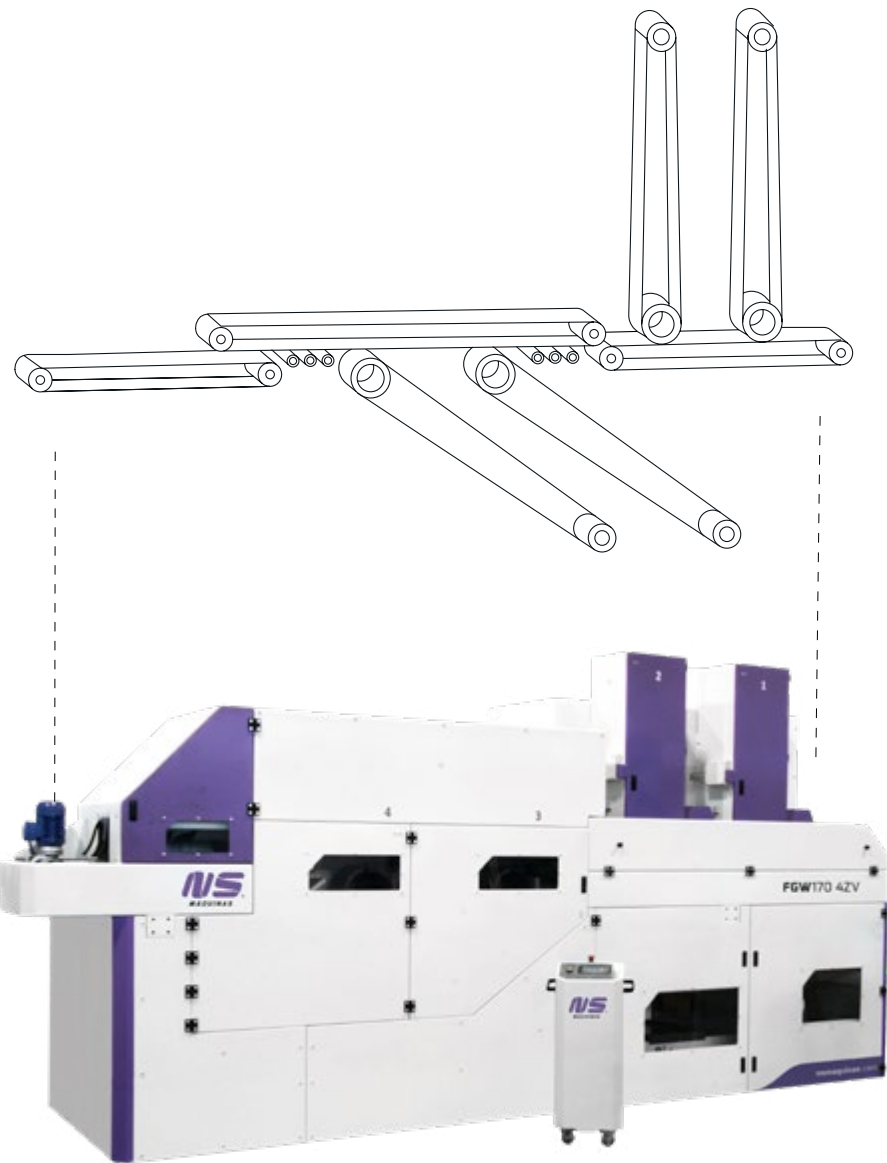

FGW170 4ZV



TR120 / BARS SIDE SURFACE GRINDING

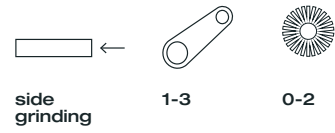

— vertical abrasive belt oscillation for a constant wear of the abrasive and a lower heat process



— machine with 2 counter rotating lamella wheels for sharp edge breaking after side grinding heads



TR120 3Z2L

TR120 2Z2L

TR120 Z2L

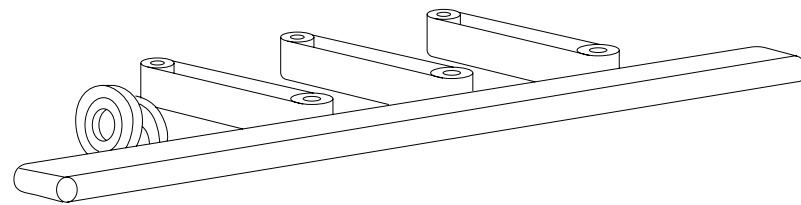

TR120 3Z



TRW120 / WATER-COOLED
BARS SIDE SURFACE GRINDING



— multiple stations on both sides of the machine enable to process the 2 sides of the flat bars

— avoid overheating of the metal parts and, consequently, material surface burning and/or distortion

scan the QR CODE to watch the machine demonstration video



TRW120 6Z4LH



DRY OPERATION

	FC120	FG170	FG220	FG330	TR120
capacity (mm) width x height	120x120	170x200	220x200	330x200	300x25
no. of abrasive belt stations	1	1	2	2	1-3
no. of abrasive brush stations	0-1	1	1	1	1
top and bottom version	×	×	FG220 4ZV	×	×

WATER OPERATION

	FCW120	FGW170	FGW220	FGW330	TRW120
capacity (mm) width x height	120x120	170x200	220x200	330x200	300x25
no. of abrasive belt stations	1	2-6	2-6	2-6	6
top and bottom version	×	FGW170 4ZV	×	×	TRW120 6Z4LH

MULTIPURPOSE

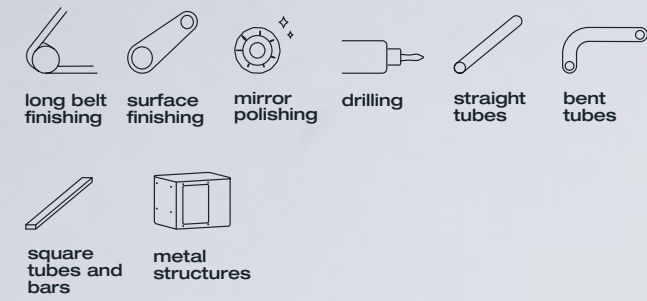

> **LONG BELT FINISHING**
ideal for large structures and finishing of irregularly shaped objects to remove welds with multiple grinding and deburring tools

> **TUBE DRILLING** with optimized drilling processes with single or dual stations, enabling precise operations for various tube and bar applications

> **MIRROR POLISHING** catering to round, square or rectangular tubes and bars with automated features and high pressure polishing

> **TUBE END DEBURRING** to remove tube sharp edges with dual rotation brush, deburring various shapes quickly without manual tube rotation

> **MULTIPURPOSE** with adaptable, multi-functional machines for metal finishing, polishing and rectification, suitable for diverse surfaces, weld seams and metal sheets

LMD

LMD2500 / LONG BELT FINISHING MACHINE



single abrasive belt



large 3D parts



deburring tool

interchange between grinding and scotch pads and edge rounding brushes



quick exchange between flat finishing tool, contact roller or manual pad



LMD2500

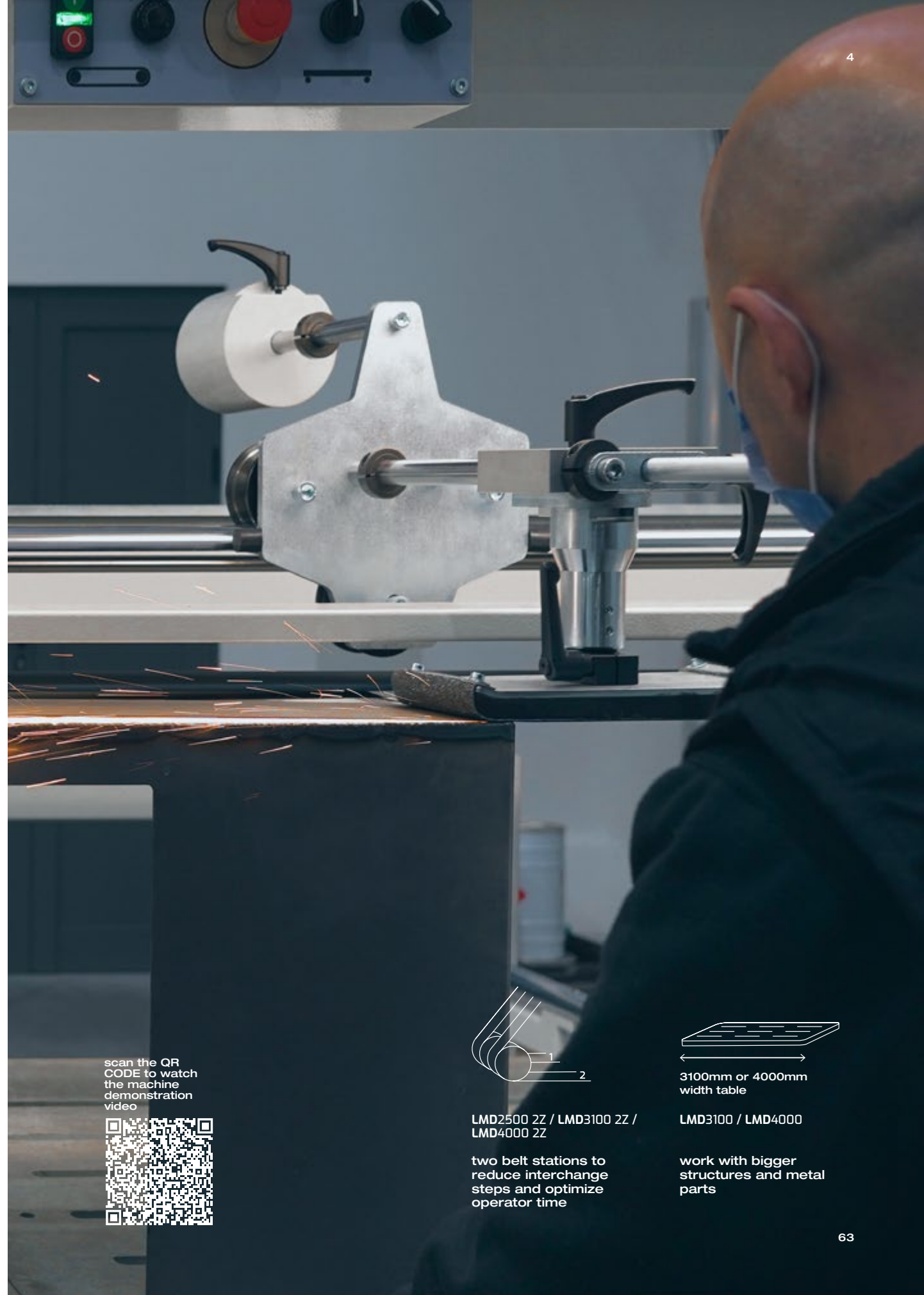
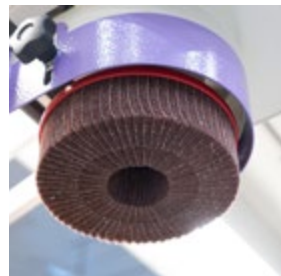

scan the QR CODE to watch the machine demonstration video



LMD2500 2Z / LMD3100 2Z / LMD4000 2Z

two belt stations to reduce interchange steps and optimize operator time

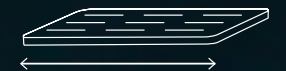

3100mm or 4000mm width table

LMD3100 / LMD4000

work with bigger structures and metal parts

LMD2500 2Z / HANDLING DEVICE



twin abrasive belt



interchangeable tools



large 3D parts



deburring tool

use different pads and brushes for orbital finishing or sharp edges removal

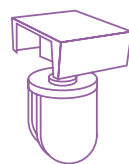

3D handling device

allows effortless movement of welded structures by easily move the part in different directions to finish each surface



LMD2500 2Z

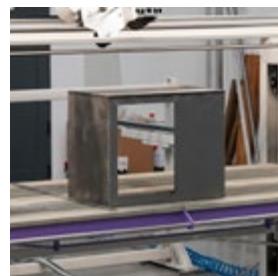

scan the QR CODE to watch the machine demonstration video



LMD2500 AT / AUTOMATED



single abrasive belt



programmable touchscreen

selectable standard programs for different finishing requirements



effortless process

the operator can do other tasks avoiding a repetitive work and the dusty process



automatic movements

tool and table movement are programmable on the touchscreen panel

MIRROR POLISHING

MP100 / ROUND TUBE POLISHING



Ø 114mm



mirror polishing



straight tube



bent tube

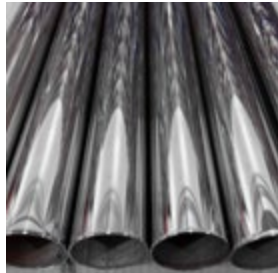

__ mirror polishing and high gloss finishing in round tubes



__ planetary polishing system that consists on three planetary polishing wheels which rotate around the tube applying high pressure

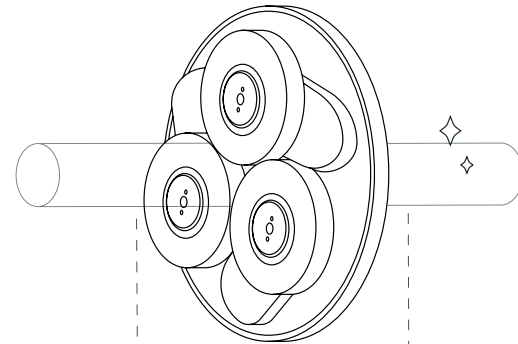

__ straight and curved tubes: capable to operating both straight tubes (automatically) and curved tubes (manually) by simply sliding the automatic feeding system



__ automatically applies soap to the polishing wheels either by the indication of the operator or by time setting



MP100

RC200 + RC250 / ROUND TUBE POLISHING AND FINISHING



Ø 250mm



mirror polishing



surface finishing



water/dry operation



straight tube



__ abrasive belt finishing



prepare the surface of the tube for mirror polishing



__ mirror polishing

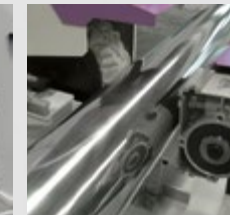

easy exchange to cotton buffing wheels for the mirror polishing process



PP220 2K / RECTANGULAR TUBE AND FLAT BAR POLISHING

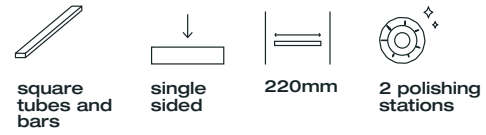

— two independent polishing stations with the possibility to adjust pressure and speed of each unit individually

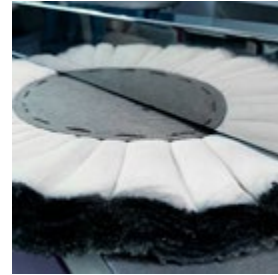

— through-feed system delivers a fast output in rectangular/square tubes and flat bars mirror polishing

PC70 2P / ROUND AND RECTANGULAR TUBE POLISHING

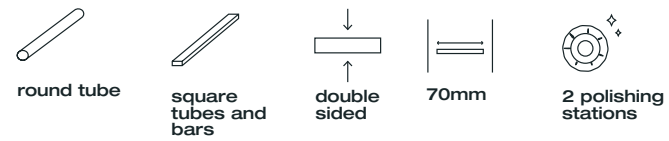

— machine developed for an automated and programmable top quality mirror polishing



— the machine is equipped with two stations contributing to a faster tube polishing, with tube internal supports for a scratch-free process



scan the QR CODE to watch the machine demonstration video



TDM

TDM100 / TUBE DRILLING MACHINE

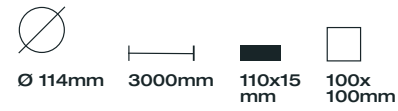

semi-automatic version



single station



TDM100

automatic version



dual-drilling station



automated process

program-saving feature and live remote monitoring



TDM100 2D AT

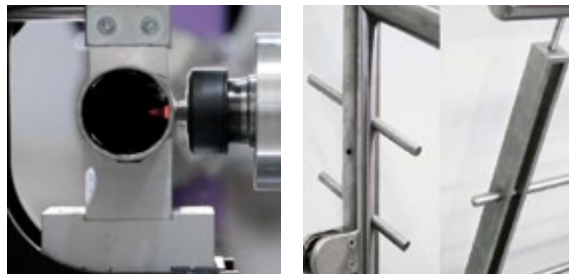

COMMON CAPABILITIES OF BOTH

TDM100 AND TDM100 2D AT



max angular drilling



max drilling diameter



drill, flowdrill and tapping



CNC SK40 fixation

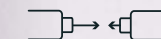

independent and precise adjustment

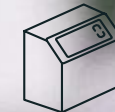

screen with angular rotation

watch the demonstration video - TDM100



watch the demonstration video - TDM100 2D AT

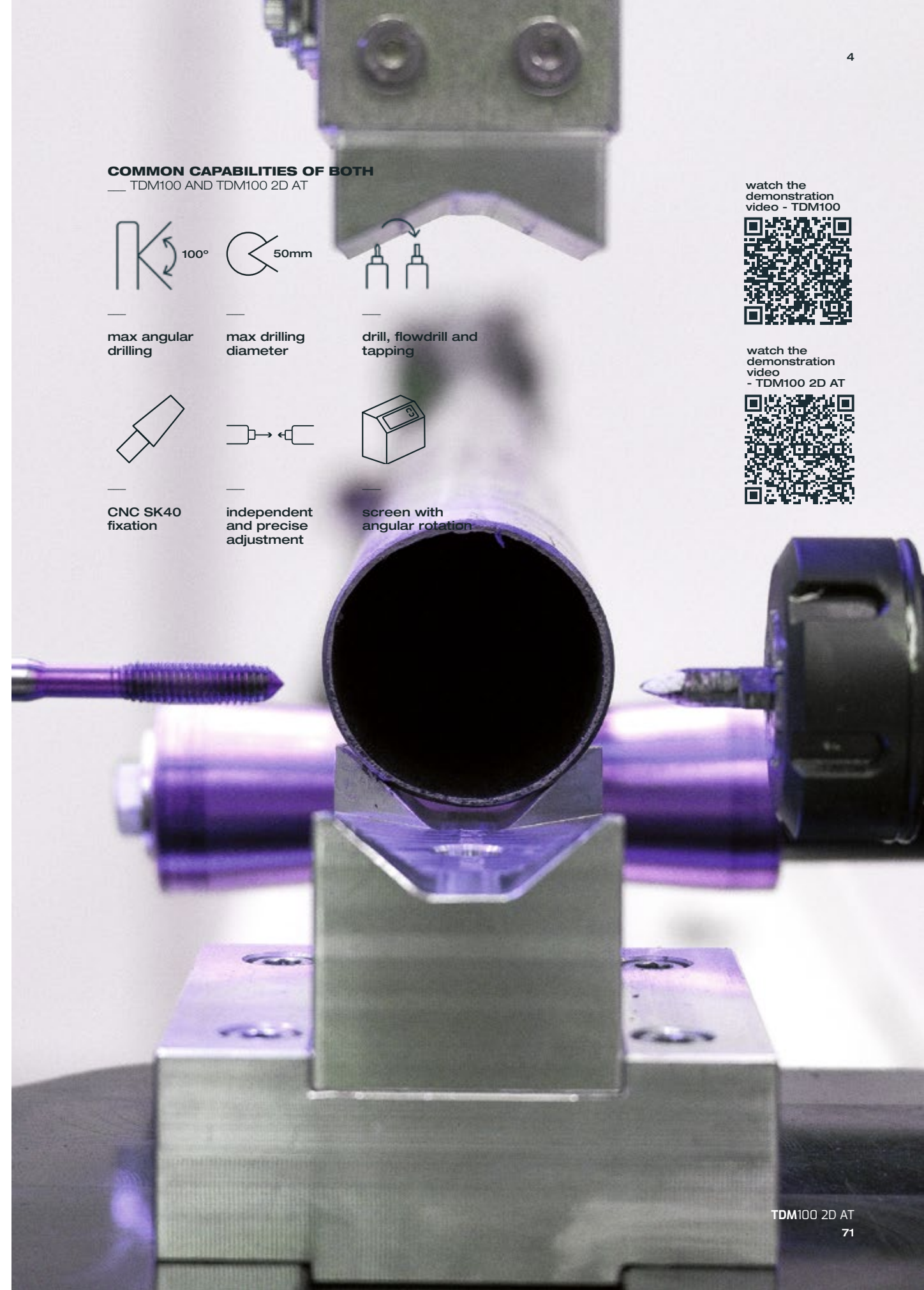

LHV200 + LV200
— TABLE BELT GRINDING MACHINES



— LV200
vertical belt with integrated stainless steel table with angular regulation and an aluminum profile guide for accurate angle positioning of metal parts



— LHV200
the abrasive belt can be used vertically or horizontally and the robust table can be adjusted in different angles to allow flexible side finishing

OD120 /
— TUBE END DEBURRING



— up to 3x faster tube end deburring since the wire brush rotates around the edge of the tube



— deburr different shapes from round to square and rectangular tubes and even aluminium profiles, treating all the edges uniformly



scan the QR CODE to watch the machine demonstration video



PL40 /
___ BELT GRINDING OR WHEEL POLISHING

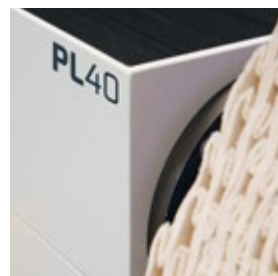

___ simple and reliable grinding and polishing machine with single motor design

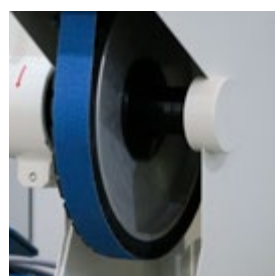

___ different configurations available with wider arms for more complex shapes processing

PL80 /
___ BELT GRINDING OR WHEEL POLISHING



___ dual motor machine with independent stations and stronger construction to operate with two workers at the same time and reduce vibration



___ the machine is available in three combinations of polishing wheels and belt grinding arms for perfect adequacy to different operations



LB50 /
___ MANUAL BELT GRINDER

___ free-belt workbench finishing and grinding machine for manual operation

___ ideal for finishing, weld seam polishing and general deburring

LR30 AT /
__ DOUBLE-SIDED SHEET METAL DEBURRING

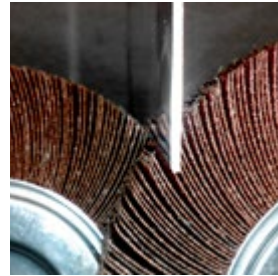

__ two abrasive lamella wheels rotate in opposite directions, removing the burr on both edges of laser or shear cut parts



__ the metal sheet is transported by a roller feeding system or manually

CLF75 /
__ MOBILE GRINDING AND POLISHING

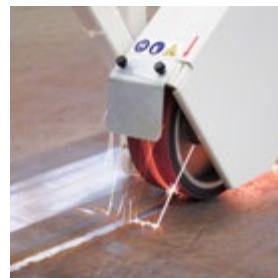

__ grinding weld seams with the contact roller

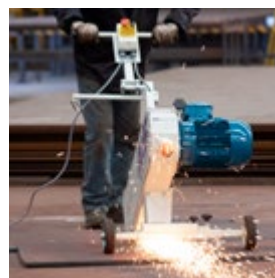

__ easy to move and use the machine along wide and heavy metal sheets

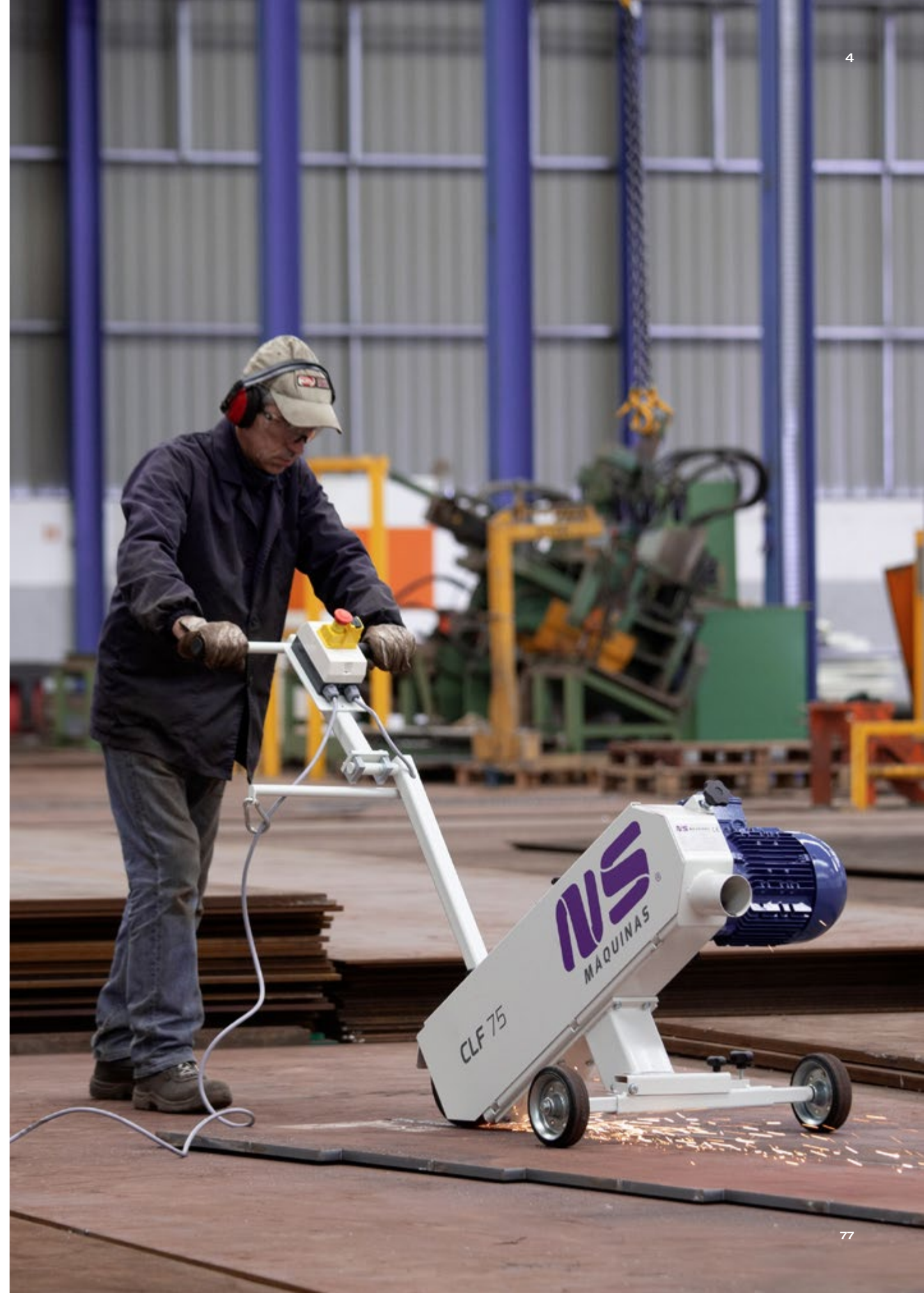



basic line extraction
— “A” series

single or double bag filters to remove and filter large particles from the surface finishing process

high efficiency extraction
— “AS” series

isolated extraction with self cleaning cartridges and spark extinguisher chamber; perfect solution for deburring and finishing machines

water operated extraction
— “AW” series

water operated filtration reduce fire risk and/or is suitable to operate with different materials; available in steel or stainless steel

LONG BELT FINISHING

	LMD2500	LMD2500 2Z	LMD2500 AT
type of station	single	double	single
type of operation	manual	manual	automatic
available width (mm)	2500 3100 4000	2500 3100 4000	2500

TUBE DRILLING MACHINES

	TDM1100	TDM100 2D AT
type of station	single	double
type of operation	semi automatic	automatic
max capacity	● 114 ■ 100X100 ■ 110X15	● 114 ■ 100X100 ■ 110X15
available length (mm)	3000	3000

MIRROR POLISHING MACHINES

	MP100	RC200 + RC250	PP220 2K	PC70 2P
metal shape	round tube	round tube	square tube and bar	round and square tube
optimization	straight and bent tubes mirror polishing	grinding and mirror polishing	flat surfaces mirror polishing	high-quality mirror polishing
max capacity (mm)	Ø114	Ø250	220x200	Ø70 or 70x70

BEHIND THE SCENES

DISCOVER, TEST, SUCCEED

Delve into NS Máquinas machines and engineering by visiting NEXUS. Join us in our dedicated building to connect with our team, explore our production facilities, and witness the power of our machines firsthand in our showroom. Expect a personalized experience tailored to showcase what is NS Máquinas.



@nsmaquinas

SOME OF OUR REFERENCES



V1 / 2024
All rights reserved

NS MÁQUINAS